

## 300mA ,500KHZ HIGH EFFICIENCY STEP-UP DC/DC CONVERTER

### DESCRIPTION

The SC46166 is a compact, high efficiency, and low voltage step-up DC/DC converter, includes an error amplifier, ramp generator, current comparator, slope compensation, current sense and driver. Peak current mode PWM control with internal compensation reduces external parts count and provides a stable and high efficient operation over a wide range of load currents.

The low start-up input voltage below 0.85V makes SC46166 suitable for 1 to 4 battery cells applications. A high switching frequency of 500kHz minimizes overall solution footprint by allowing the use of tiny, low profile inductors and ceramic capacitors. The SC46166 shifts automatically to Power Saving Mode operation at light loads, the 20uA low quiescent current together with high efficiency maintains long battery lifetime. The device also features low shutdown current of under 1μA.

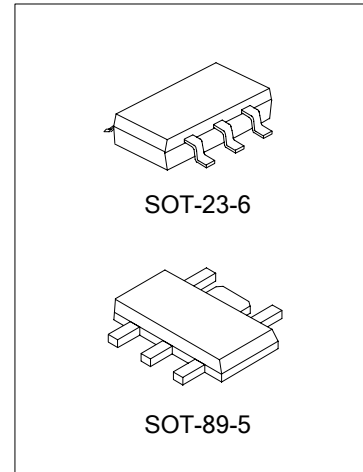

### FEATURES

- \* 0.85V Low Start-up Input Voltage
- \* High Supply Capability to Deliver 3.3V 100mA with 1 Alkaline Cell
- \* Automatic Power Saving Mode Operation with 20μA Quiescent Supply Current
- \* Up to 90% Efficiency
- \* Output Range: 2.5V to 6V
- \* Shutdown Mode Supply Current : <1uA
- \* 500kHz Fixed Switching Frequency
- \* Over Temperature Protection
- \* 4KV HBM ESD
- \* Small SOT-23-6 & SOT-89-5 Package

### APPLICATIONS

- \* MP3 Players
- \* Digital Cameras
- \* PDA
- \* LCD Bias Supplies
- \* Portable Instrument
- \* Wireless Equipment

### ORDERING INFORMATION

Device	Package	Seal
SC46166	SOT-23-6	46166
SC46166S	SOT-89-5	46166S

**BLOCK DIAGRAM**

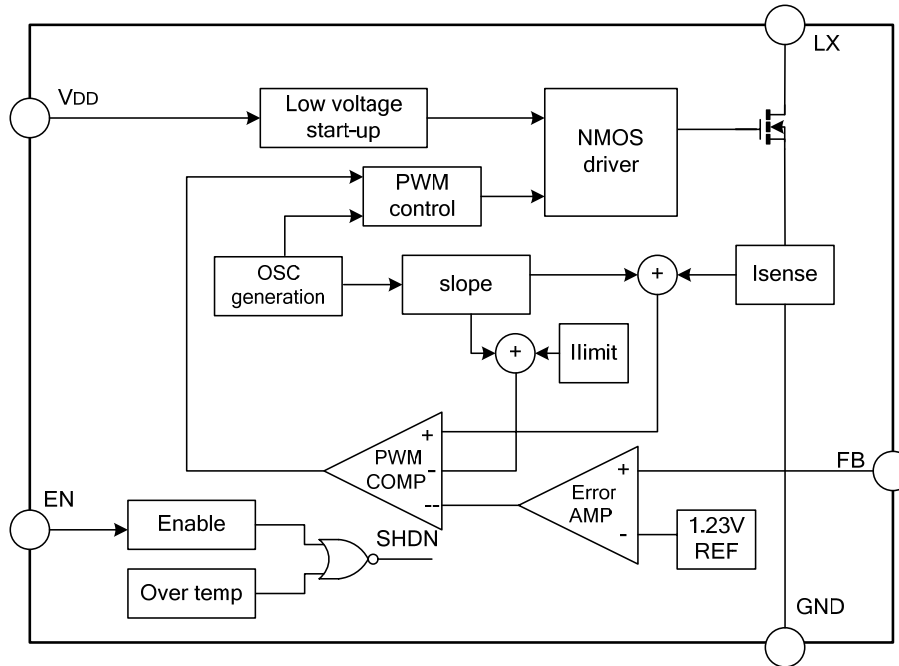

**ABSOLUTE MAXIMUM RATINGS** ( $T_{amb}=25^{\circ}C$ )

Characteristics	Rating	Unit
VDD Supply Voltage	-0.3~+6	V
LX Voltage	-0.3~+6	V
EN Voltage	-0.3~+6	V
FB Voltage	-0.3~+6	V
Operating Temperature	-40 ~ + 85	$^{\circ}C$
Storage Temperature	-65 ~ +125	$^{\circ}C$

**ELECTRICAL CHARACTERISTICS** ( $T_{amb}=25^{\circ}C$ ,  $V_{IN}=1.5V$ ,  $V_{DD}=3.3V$ , Load Current=0 Unless otherwise specified)

Characteristics	Symbol	Test condition	Min.	Typ.	Max.	Unit
Minimum Start-Up Voltage	VST	$I_L=1mA$ , Measured On VDD	--	0.85	0.9	V
Operating VDD Range	VDD	VDD pin voltage	2.5	--	6	V
Feedback Reference Voltage	VFB		1.2	1.23	1.26	V
Quiescent Current (Power Saving Mode)	$I_{switch\ off}$	FB=1.4V	--	20	30	$\mu A$
Quiescent Current (Shutdown)	$I_{st}$	EN=0V	--	0.1	1	$\mu A$
Quiescent Current (PWM active Mode)	$I_Q$	Measured On VDD, Nonswitching	--	300	360	$\mu A$

Characteristics	Symbol	Test condition	Min.	Typ.	Max.	Unit
Power Saving Mode Current Threshold	I <sub>load</sub>	L=4.7μH	--	7.5	--	mA
Line Regulation	ΔV <sub>LINE</sub>	1V≤V <sub>IN</sub> ≤3 V	--	2	10	mV/V
Load Regulation	ΔV <sub>LOAD</sub>	1mA≤I <sub>L</sub> ≤100mA	--	0.1	1	mV/mA
Switching Frequency	F <sub>s</sub>	--	450	500	550	KHz
Max Duty Cycle	D <sub>MAX</sub>	FB=1.2V	90	95	--	%
NMOS Switch On Resistance	R <sub>ON</sub>	V <sub>DD</sub> =3.3V	--	0.4	0.5	Ω
NMOS Switch Leakage	I <sub>leak</sub>	V <sub>LX</sub> =5V	--	0.1	1	μA
NMOS Current Limit	I <sub>LIMIT</sub>		0.75	1	1.25	A
EN Input High	V <sub>H</sub>	--	1	--	--	V
EN Input Low	V <sub>L</sub>	--	--	--	0.35	V
Thermal Shutdown Temperature	T <sub>j(sd)</sub>	--	--	150	--	°C
Thermal Shutdown Hysteresis	T <sub>hyst</sub>	--	--	20	--	°C

## PIN CONFIGURATION

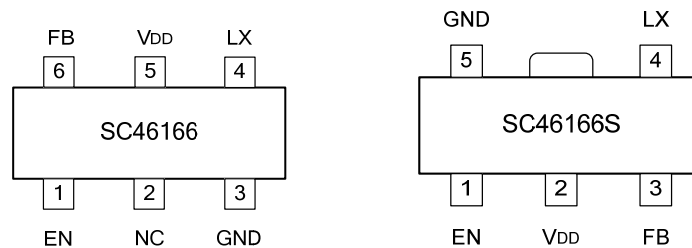

## PIN DESCRIPTION

Pin No.		Pin Name	I/O	Pin Description
SC46166	SC46166S			
1	1	EN	I	Chip Enable (Active High)
2	—	NC	—	Not connect
3	5	GND	G	Ground
4	4	LX	I/O	Switch Pin. Connect inductor between LX and V <sub>IN</sub>
5	2	VDD	P	Power Supply Pin of SC46166
6	3	FB	I	Feedback Input Pin

## FUNCTION DESCRIPTION

The SC46166 is a 500kHz, asynchronous boost converter housed in a compact package, includes a voltage reference, error amplifier, ramp generator, current comparator, slope compensation, current sense and driver.

The low start-up function allows SC46166 operating from an input voltage below 1V, 0.85V typically at V<sub>DD</sub>. In

current mode PWM operation, SC46166 automatically detects the output, if the output load current falls below an internally programmed threshold (The threshold has an dependence on the input voltage, output voltage and also the value of the external inductor.), it shifts to Power Saving Mode operation, in which the IC consumes only 20μA, the efficiency is increased. However, the output ripple typically increases. Power Saving Mode ripple can be reduced, by placing a small feed-forward capacitor (An empirical suggestion is around 0.1~10nF) between V<sub>OUT</sub> and FB pins.

Operating at heavy loads for a long time, the die temperature will rise, if the die temperature continues to rise and reaches 150°C, the device shuts off entirely, the part will be enabled again when the die temperature drops by about 20°C.

## APPLICATIONS INFORMATION

### Output Voltage Setting

Referring to the figure1, the output voltage of the switching regulator (V<sub>OUT</sub>) can be set with Equation following:

$$V_{OUT} = \left(1 + \frac{R1}{R2}\right) \times 1.23V$$

### Feedback Loop Design

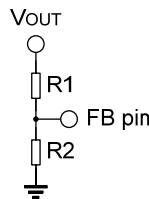

Referring to Application Circuit of figure1, the selection of R1 and R2 are based on the trade-off between quiescent current consumption and interference immunity. Higher R reduces the quiescent current (Path current = 1.23V/R2), however resistors beyond 5MΩ, are not recommended. Lower R gives better noise immunity, and is less sensitive to interference, layout parasitics, FB node leakage, and improper probing to FB pins. A proper value of feed-forward capacitor C1 parallel with R1 can improve the noise immunity of the feedback loops, especially in an improper layout. An empirical suggestion is around 100pF~1nF for feedback resistors of MΩ, and 10nF~100nF for feedback resistors of hundreds kΩ.

## COMPONENT SELECTION

### ◇ Inductor Selection

The SC46166 can utilize small surface mount and chip inductors due to its fast 500kHz switching frequency. Typically, a 4.7μH inductor is recommended for most applications. Larger values of inductance will allow greater output current capability by reducing the inductor ripple current. Increasing the inductance above will also increase size.

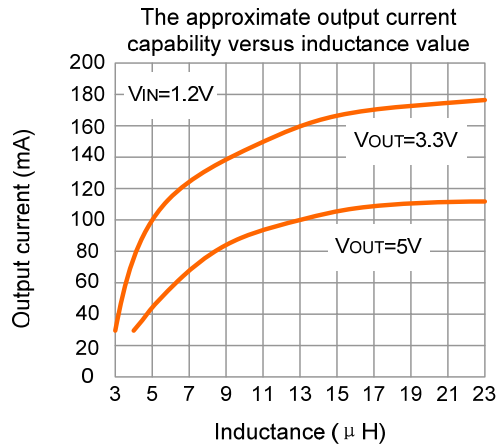

The inductor current ripple is typically set for 20% to 40% of the maximum inductor current (IP). The inductor should have low ESR (series resistance of the windings) to reduce the power losses, and must be able to handle the peak inductor current without saturating. To minimize radiated noise, use a shielded bobbin inductor.

#### ◇ Output and Input Capacitor Selection

Low ESR (equivalent series resistance) capacitors should be used to minimize the output voltage ripple. Multilayer ceramic capacitors are an excellent choice as they have extremely low ESR and are available in small footprints. A 10μF to 22μF output capacitor is sufficient for most applications. Larger values may be used to obtain extremely low output voltage ripple and improve transient response.

Low ESR input capacitors reduce input switching noise and reduce the peak current drawn from the battery. It follows that ceramic capacitors are also a good choice for input decoupling, and should be located as close as possible to the device. A 4.7μF input capacitor is sufficient for virtually any application.

Operating at light loads, an additional feed forward capacitor may be required (for example C1 in the Figure 1) to maintain acceptable output voltage ripple.

For all the three capacitors above, X5R and X7R dielectric materials are preferred, for their ability to maintain capacitance over wide voltage and temperature ranges.

TYPICAL ELECTRICAL CHARACTERISTICS CURVES ( $T_{amb}=25^{\circ}C$ , Unless otherwise specified)

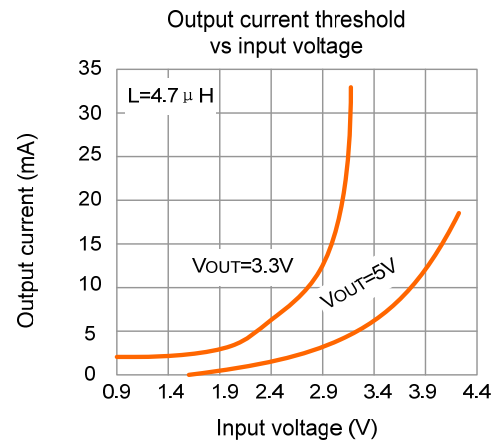
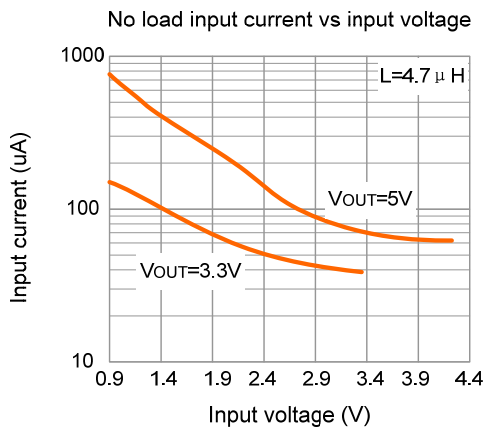
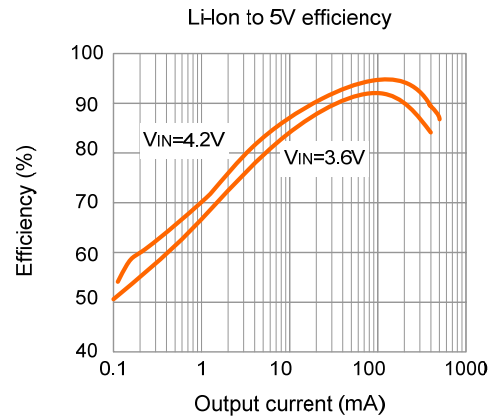
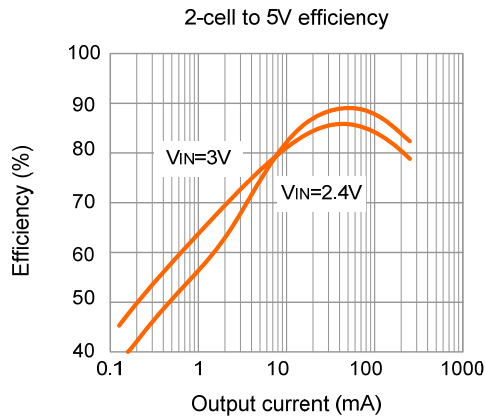
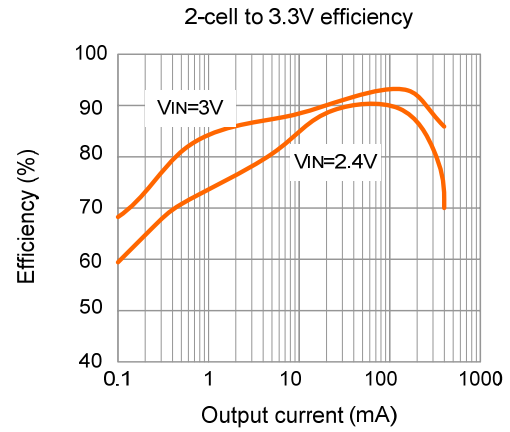
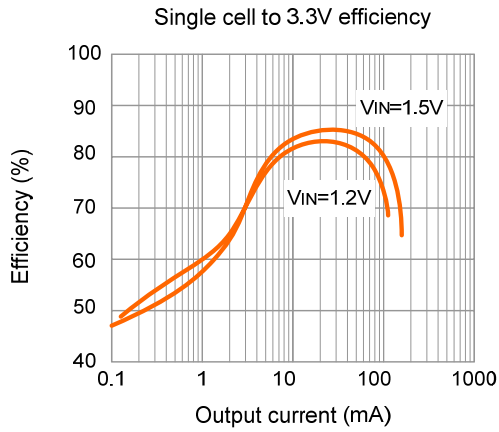

(To be continued)

(Continued)

**TYPICAL ELECTRICAL CHARACTERISTICS CURVES** ( $T_{amb}=25^{\circ}C$ , Unless otherwise specified)

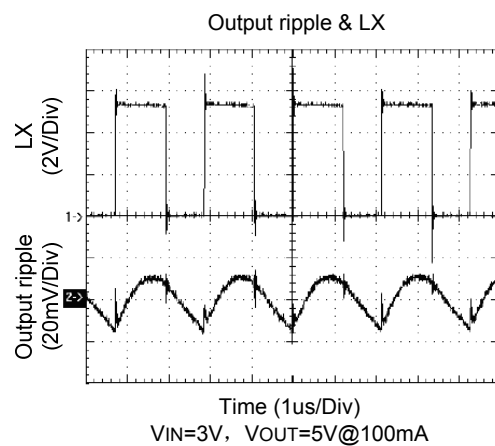
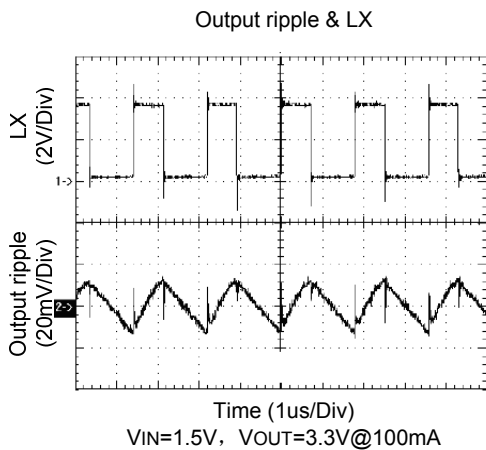
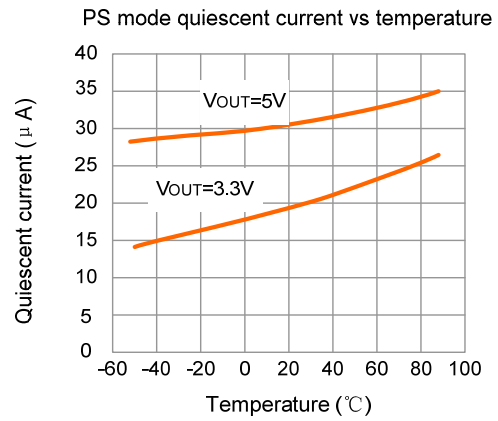
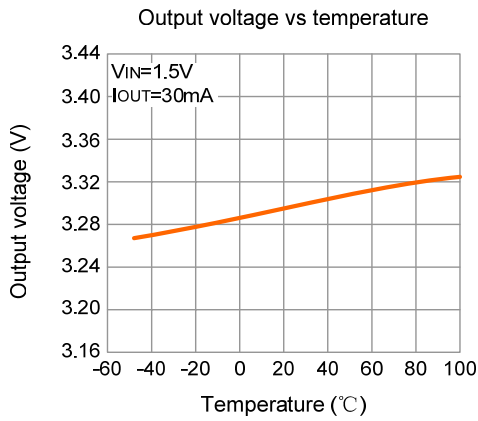
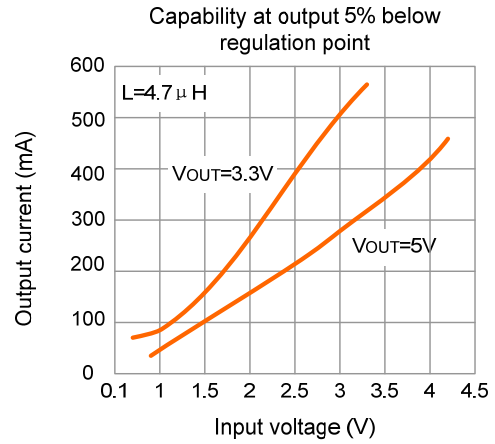
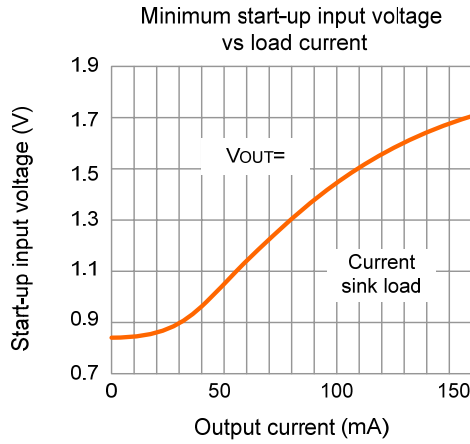

**TYPICAL APPLICATION CIRCUIT**

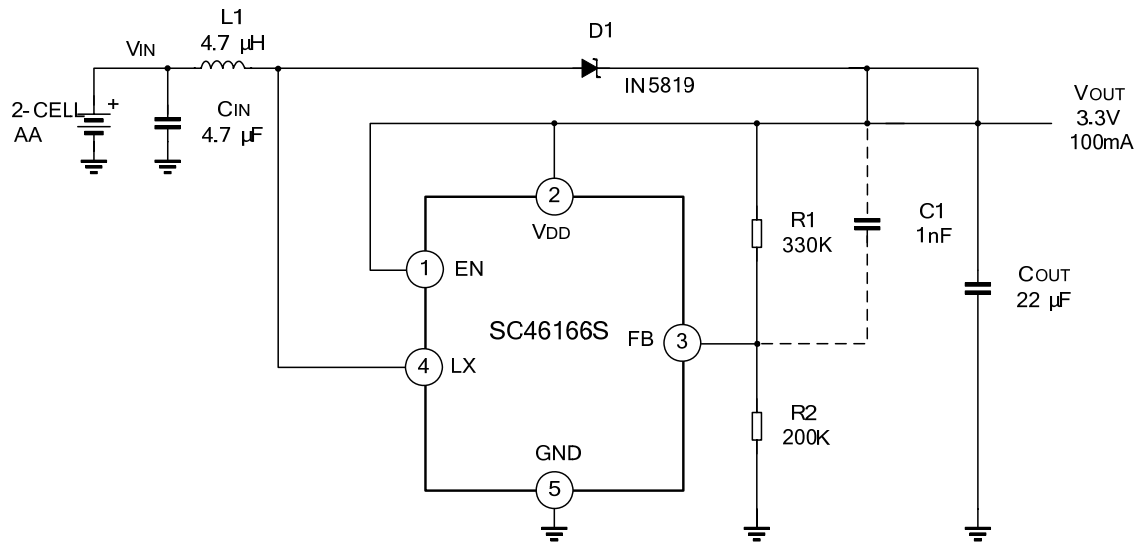

Figure 1. Application Circuit for 2-Cell to 3.3V Boost Converter

Note: The circuit and parameters are reference only, please set the parameters of the real application circuit based on the real test .



PACKAGE OUTLINE

SOT-23-6

UNIT: mm

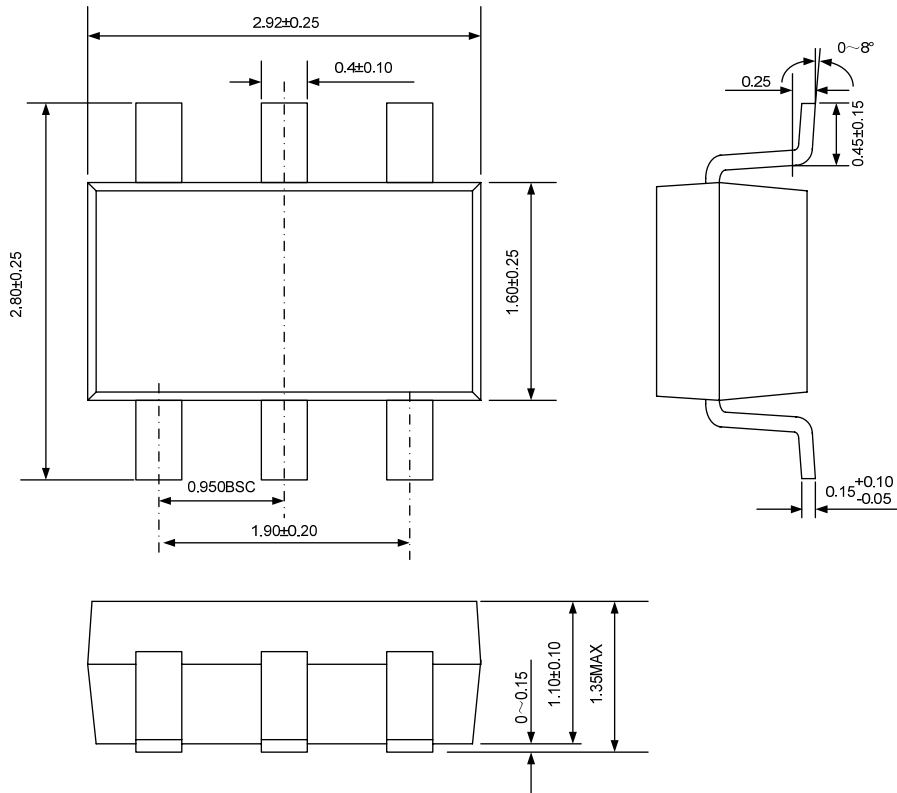

SOT-89-5

UNIT: mm

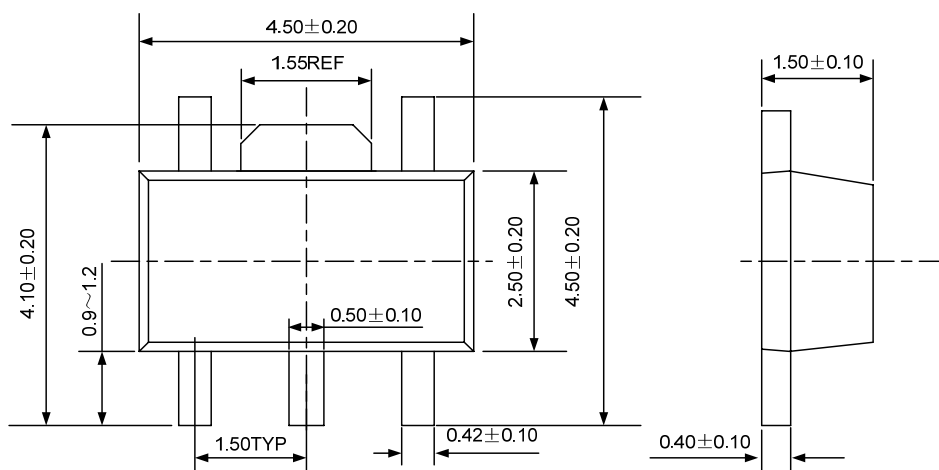



#### HANDLING MOS DEVICES:

Electrostatic charges can exist in many things. All of our MOS devices are internally protected against electrostatic discharge but they can be damaged if the following precautions are not taken:

- Persons at a work bench should be earthed via a wrist strap.
- Equipment cases should be earthed.
- All tools used during assembly, including soldering tools and solder baths, must be earthed.
- MOS devices should be packed for dispatch in antistatic/conductive containers.

Note: Silan reserves the right to make changes without notice in this specification for the improvement of the design and performance. Silan will supply the best possible product for customers.